

DIXIE GRINDERS INC.

1324 RAILROAD AVENUE GUNTERSVILLE, AL 35976
(800) 745-0586 (256) 582-0477 FAX (256) 582-0478

MODEL 11-9
GRINDER UNIT



CAUTION

**THIS MANUAL MUST BE READ TO,
OR BY EACH PERSON, BEFORE
THAT PERSON OR DEPARTMENT
UNCRATES, OPERATES,
MAINTAINS, OR SUPERVISES USE
OF THIS MACHINE IN ANY WAY.**

SAFETY INSTALLATION OPERATION MAINTENANCE



KNOW YOUR MACHINE

READ OPERATING & SERVICE INSTRUCTIONS BEFORE INSTALLING PARTS OR SERVICING MACHINE IN ANY MANNER, BE SURE THAT MACHINE IS STOPPED AND ALL POWER IS OFF AND LOCKED OUT. THIS INCLUDES ELECTRICAL, HYDRAULIC, AIR, STEAM, ETC. FAILURE TO FOLLOW THIS RULE, OR TO PRACTICE SAFE OPERATING PROCEDURES CAN RESULT IN SEVERE PHYSICAL INJURY.

INTRODUCTION

A Grinder Unit is a type of size reduction machine. Its primary purpose is to grind meat, meat by-products, and other similar products.

The primary grinding components are a plate retaining ring, orifice plate, plate bushing, knifeholder with knife inserts, centering pin, spring or springs, head, feedscrew, hopper, gearbox, and drive pulleys. In most instances an electric motor drives the grinder unit.

This unit is mounted on a undermount frame (as shown on cover) or sidemount frame.

Standard safety equipment includes a belt guard, a hopper guard, and a plate guard. If a transition funnel is used, the plate guard is not required.

It is important that your application, and/or installation does not render these guards ineffective. If for any reason you believe these guards are not adequate, do not use the machine and call Dixie Grinders Inc. at once. (256) 582-0477 OR (800) 745-0586.

This machine was sold for a specific application. If you are not familiar with the application that this unit was sold for, check with Dixie Grinders Inc. before using the machine.

All operators and sanitation personnel should read this manual and understand it.

THE HOPPER GUARD AND PLATE GUARD MAY NOT BE ATTACHED FOR SHIPPING!

FAILURE TO USE GUARDS WHILE THE GRINDER UNIT IS IN OPERATION MAY RESULT IN SEVERE INJURY OR DEATH!

THE HOPPER GUARD IS PROVIDED TO RESTRICT ACCESS TO THE ROTATING FEEDSCREW!

THE PLATE GUARD IS PROVIDED TO RESTRICT ACCESS TO THE PLATE, THE KNIFEHOLDER, AND THE FRONT END OF THE FEEDSCREW!

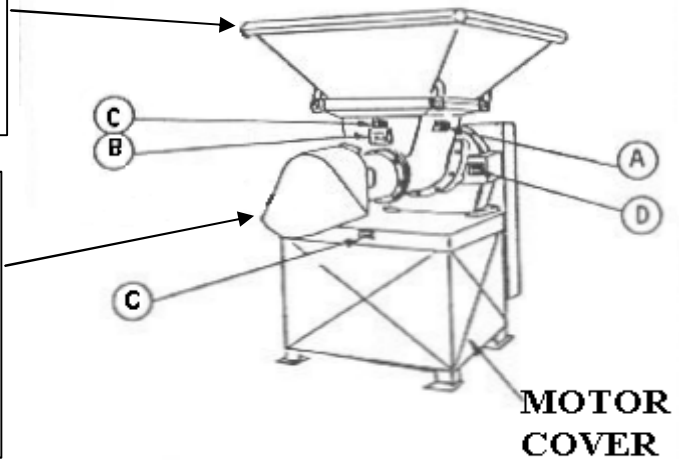

REPLACE SAFETY TAGS WHEN NECESSARY! CALL DIXIE GRINDERS INC. FOR REPLACEMENT SAFETY TAGS.

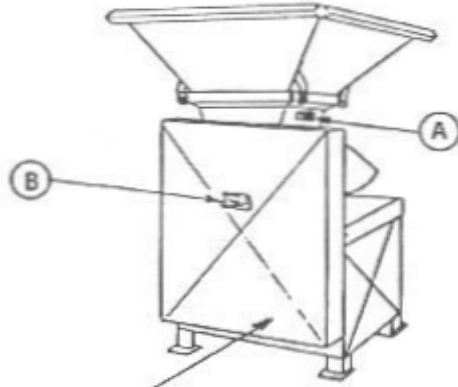

TAG C 2 EA. (ON FRONT OF HOPPER AND FRONT OF FRAME)

THE BELT GUARD IS PROVIDED TO RESTRICT ACCESS TO THE V BELTS AND THE ROTATING PULLEYS!



TAG A 2 EA. (ON SIDES OF HOPPER)

KNOW YOUR MACHINE

READ OPERATING & SERVICE INSTRUCTIONS BEFORE INSTALLING PARTS OR SERVICING MACHINE IN ANY MANNER, BE SURE THAT MACHINE IS STOPPED AND ALL POWER IS OFF AND LOCKED OUT. THIS INCLUDES ELECTRICAL, HYDRAULIC, AIR, STEAM, ETC. FAILURE TO FOLLOW THIS RULE, OR TO PRACTICE SAFE OPERATING PROCEDURES CAN RESULT IN SEVERE PHYSICAL INJURY.

TAG B 2 EA. (ON BELT GUARD AND ON HOPPER FRONT)

"THE GRINDER HAS ARRIVED"

LIFT EQUIPMENT REQUIRED:

We recommend using a 5,000 pound capacity fork lift with 48" or longer forks. Do not attempt to unload the grinder unit from a commercial van from ground level! Only authorized and properly trained equipment movers should attempt to unload the grinder unit. Remember to Work Safely!

PRE-UNLOADING INSPECTION:

Before the grinder unit is unloaded, inspect the unit for any damage before unloading. If the machine is damaged consult your management, the trucking company, and Dixie Grinders Inc. **before unloading the machine!**

UNLOADING GRINDER UNIT:

With the commercial van properly chocked and secured to the loading dock, and using only approved and adequate dock plates should any attempt be made to unload this machine. Lift only under the grinder frame, never attempt to pick up a grinder from the hopper or gearbox. The forks should be long enough to extend beyond the end of the frame a safe distance. Unload the grinder unit and all parts that have been shipped with the grinder unit. Consult the packing slip to insure that all pieces have been unloaded.

UNPACKING:

When the grinder has been properly unloaded it should be placed in a suitable location for unpacking. The belt guard protector and the shipping skids may be removed. Remove any spare parts that may have been shipped in the grinder hopper. Use appropriate equipment and appropriate personal safety equipment in this process. Remember to Work Safely!

SITE CONSIDERATIONS:

It is important that the permanent position of the grinder unit provides clearance of several feet behind, to either side, and approximately eight feet or more in front of the grinder unit.

If the grinder is set on a stand, or leg extensions are attached, an adequate platform must be provided to provide safe access to the grinder unit. It will be necessary to have an approved platform or device to provide access so the unit can be properly sanitized, disassembled, assembled, and maintained. Consideration must be given to allow for complete service to the grinder unit.

Platforms should be so designed not to make the hopper guard, or other guarding, ineffective. The hopper guard is not a hopper for holding a large amount of material, it is designed to keep the operator away from the feedscrew. If the location of this grinder unit compromises this feature, special guarding may be necessary. Consult your Safety Engineer, Plant Engineer, and O.S.H.A. for all regulations related to the guarding of this machine.

Only the feedscrew puller and ring lift can be attached to the grinder unit directly. Do not use the grinder frame to support other equipment without prior approval from Dixie Grinders Inc. The grinder frame is not to be used as a personal stand, and under no circumstances should anyone be allowed to climb on it or use it as a platform. Remember to Work Safely!

INSTALLATION:

The machine can be installed in its permanent position after the skidding has been removed. Use only adequate equipment and properly trained personnel to install the grinder in its permanent position. Use great care in moving this equipment, it is heavy and must not be tipped, tilted, jarred or jammed into position. We recommend a 1° slope to allow water to drain from the grinder unit.

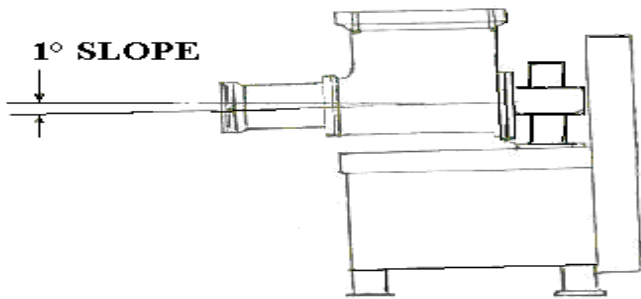

UNIT CONTROLS.

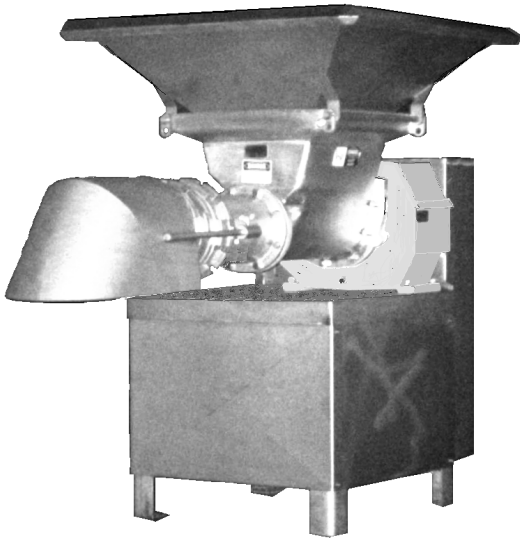

Dixie Grinders Inc. does not supply motor controls, starters, stop/start stations, disconnects, or other related equipment that is required to control the function of the grinder unit.

We recommend serious consideration is given to the location of the start/stop station.

We strongly recommend that additional stop stations are located where deemed appropriate.

Disconnects that can be locked out should be so located that employees that have to operate, service, and sanitize the unit can lock the unit out. Each employee that has to work on this machine should be given a lock and key and trained in proper procedures for LOCK OUT/TAG OUT!

Please consult with your Safety Engineer, your Electrical Engineer, and O.S.H.A. for all regulations related to the controls and wiring for this machine.

We do not recommend the use of wye-delta or star delta starters. In some areas this is required. If your machine must be wired this way the operators must understand that they cannot begin to grind product until full power is supplied to the grinder feedscrew. If there is product in the grinder hopper before the unit is turned on, the grinder may not have enough torque to start grinding in the reduced torque condition.

Frequency controllers are very useful, but with the exception of a grinder connected directly to a pump unit or mechanical deboner, the use of a frequency controller on a grinder unit is usually not necessary. We do recommend a frequency controller or some form of speed control is used to feed the grinder, and often to take the product away from the grinder.

We do not recommend remote operation of any grinder unit unless special precautions are taken, and that all possibilities of employee injury are eliminated.

DISASSEMBLY TOOLS:

If the grinder is not located on floor level make no attempt to disassemble the grinder unit without an adequate platform or provisions provided by the installation contractor, plant engineer, or plant safety officer. The grinder has many parts that have square edges and cutting edges. Adequate safety equipment should be used at all times!

After the grinder has been installed in its permanent position, it can be disassembled.

The tools described below are for both disassembly and assembly of the grinder unit.

Ring Wrench

The Ring Wrench fits over the lugs of ring and is used to loosen the ring (counter clockwise), or tighten the ring (clockwise)



The end of the ring wrench fits into the end of the feedscrew and it can be used to engage the feedscrew to the drive spline.

Plate Lifter

This is used to remove the plate and bushing from the grinder unit, or on assembly to install the plate and bushing into the grinder unit.



Note:

Wear appropriate safety equipment and remember to always "Work Safely".

GRINDER UNIT DISASSEMBLY:

READ AND UNDERSTAND THE FOLLOWING TAG.



When the grinder unit has been properly secured, disassembly can begin.

Step 1. Using the ring wrench, loosen the ring by exerting downward pressure, as shown, turning the ring counter clockwise.

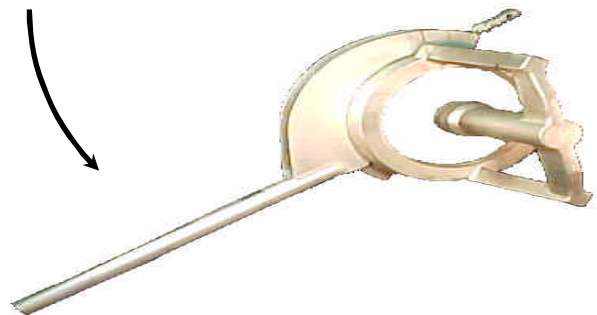

POWER LOCKED OUT!

Use the ring wrench only to loosen the ring, when the ring can be turned by hand, discontinue using the ring wrench.

Step 2. When the ring has been loosened turn it off by hand. Depending on the ring type, the ring may weigh up to 65 lbs. If this is more than you can lift, get help. Use the ring remover if your machine has been equipped with one. Do not attempt to remove the ring if you are out of position, or if the ring is higher than the center of your chest, or if you cannot lift this much on your own! Do not bang the ring threads against the centering pin!

Step 3. PLATE REMOVAL:

Using the plate lifter, remove the plate and bushing from the grinder unit. It is necessary to lift while pulling on the bushing. Do not use screwdrivers or other tools to pry the plate from the grinder unit.



POWER LOCKED OUT!

Step 4. KNIFEHOLDER REMOVAL:

Remove the knifeholder from the face of the grinder. The knife inserts are sharp, so wear appropriate gloves.

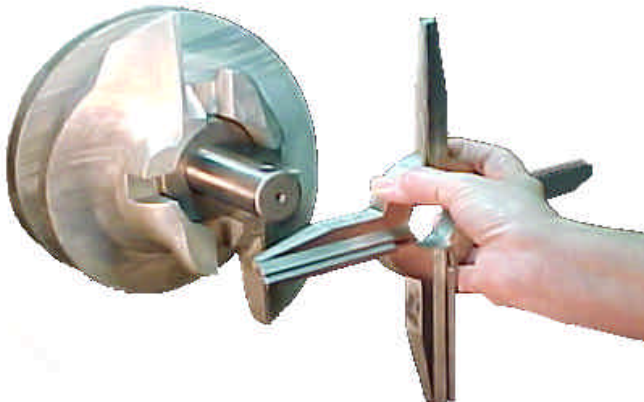

POWER LOCKED OUT!

Step 5. REMOVE SPRINGS: Remove the Belleville springs, 2 each. Some pins have a spacer collar behind the Belleville springs, if this collar is used, remove it also.

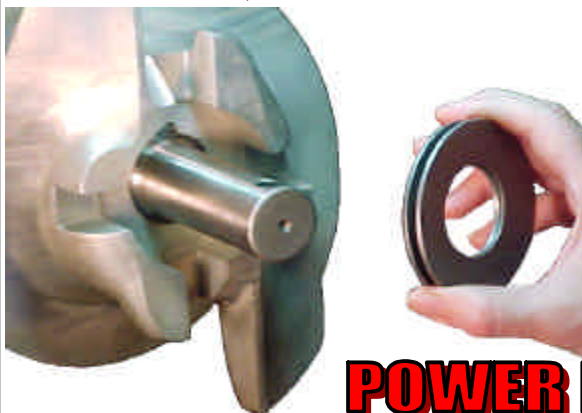

POWER LOCKED OUT!

Step 6. REMOVE THE CENTERING PIN



POWER LOCKED OUT!

Do not loose the pin key when you are removing the pin!



Step 7. REMOVE THE FEEDSCREW FROM THE GRINDER UNIT.

We recommend using our Model FSP2005 to remove the feedscrew (see next page). If you do not have a FSP2005 feedscrew puller, we recommend using a worm cart, chain hoist, or other suitable lifting device.

The feedscrews are heavy, 300 to over 400 pounds. Do not attempt to remove the feedscrew by hand.

The feedscrew needs to be handled carefully so that the outside diameter is kept free of nicks and burrs. Be careful, the feedscrew has sharp corners that can cut, the cupping is sharp!

Wear appropriate safety equipemnt and remember to always "Work Safely".

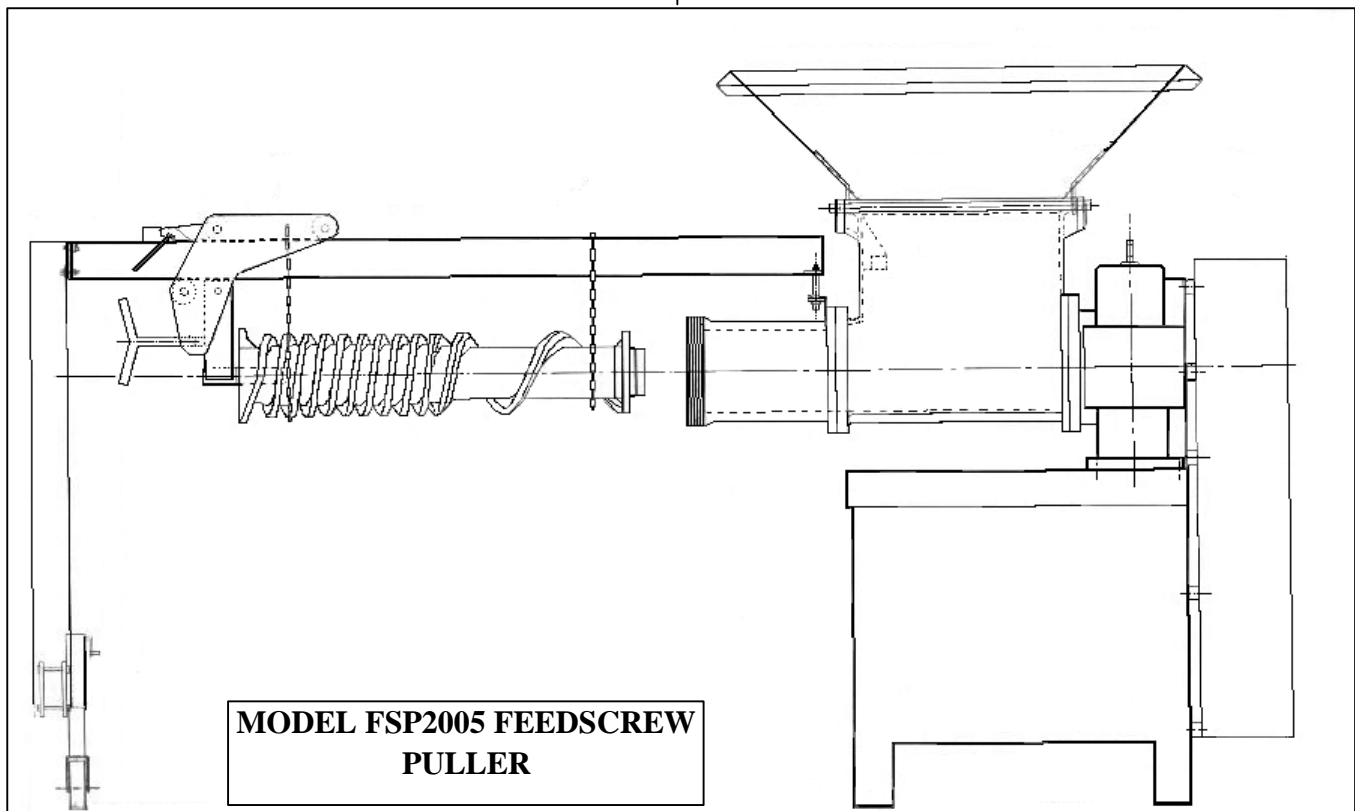

With the feedscrew removed from the grinder unit, it can now be wired. Dixie Grinders Inc. does not supply motor controls, disconnects, or stop/start stations. Please consult your Electrical Engineer, your Safety Engineer, OSHA, and other Federal, State, and local regulations.



KNOW YOUR MACHINE

READ OPERATING & SERVICE INSTRUCTIONS BEFORE INSTALLING PARTS OR SERVICING MACHINE IN ANY MANNER, BE SURE THAT MACHINE IS STOPPED AND ALL POWER IS OFF AND LOCKED OUT. THIS INCLUDES ELECTRICAL, HYDRAULIC, AIR, STEAM, ETC. FAILURE TO FOLLOW THIS RULE, OR TO PRACTICE SAFE OPERATING PROCEDURES CAN RESULT IN SEVERE PHYSICAL INJURY.

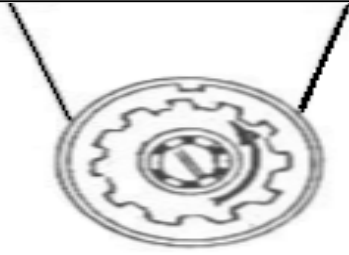

ROTATION: When the grinder unit has been disassembled, and then wired according to all applicable codes and regulations, rotation can be checked. **Do not turn the unit on until you are positive that no one is in harms way!** The grinder feedscrew should turn counterclockwise! After the rotation has been checked **LOCK OUT THE POWER!**



KNOW YOUR MACHINE
READ OPERATING & SERVICE INSTRUCTIONS BEFORE INSTALLING PARTS OR SERVICING MACHINE IN ANY MANNER. BE SURE THAT MACHINE IS STOPPED AND ALL POWER IS OFF AND LOCKED OUT. THIS INCLUDES ELECTRICAL, HYDRAULIC, AIR, STEAM, ETC. FAILURE TO FOLLOW THIS RULE, OR TO PRACTICE SAFE OPERATING PROCEDURES CAN RESULT IN SEVERE PHYSICAL INJURY.

SANITATION: Appropriate clothing should be worn, and all safety precautions should be taken before cleaning any equipment. Typical grinder units have tin plated feedscrews, heads, rings, and often the grinder hopper is also tin plated. Before you begin to clean your machine, make sure any commercial cleaning agents are approved for cleaning tin plated surfaces. If no mention of tin is on the label but the cleaner is not recommended for aluminum do not use it unless you have contacted the cleaner manufacturer for their recommendations. Do not use high pressure streams of water to clean a grinder unit. It is possible to drive water past the oil seals and damage the gearbox.

Do not allow any cleaning agent to sit on the tin plated surfaces for an extended period of time. Apply the soap, and rinse it off immediately!

After cleaning, rinse the unit with large quantities of hot water. We strongly recommend drying the unit and applying a liberal amount of mineral oil to all tin plated surfaces. If the machine is not going to be used for an extended period, apply a coat of edible grease to all surfaces and wrap the grinder in plastic.

SANITIZERS: Iodine sanitizers. Iodine reacts with tin. If the Iodine is in sufficient strength and has been on the tin plated surfaces long enough it will turn anything that touches the surface deep purple. Other sanitizers also may react with tin plated or stainless steel surfaces. Check label instructions before using. If you notice that the tin plating is coming off of your grinder unit contact Dixie Grinders Inc.

UNIT ASSEMBLY: Please study all of the grinder parts shown on the exploded view before you attempt to assemble the grinder unit. The exploded view is at the rear of the maintenance instructions. (These instructions assume that the grinder unit has not been disassembled any further than the instructions already given.)

MAKE SURE THE POWER IS STILL LOCKED OUT BEFORE ASSEMBLY.

Step 1. INSTALL FEEDSCREW.

Using the Model FSP2001 feedscrew puller, or other device, install the feedscrew into the grinder unit. Do not attempt to install the feedscrew by hand, or by yourself. You will notice that when using the FSP2001 the feedscrew usually engages on the drive spline with little effort. If you are not using the FSP2001 it will be necessary to use the handle end of the ring wrench.

POWER LOCKED OUT!

POWER LOCKED OUT!

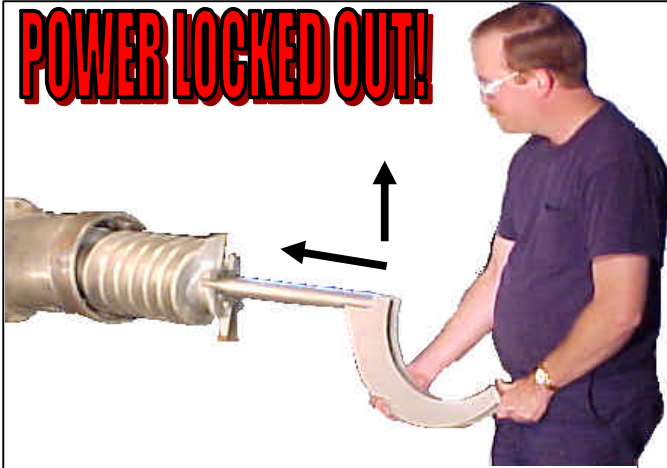

When using the ring wrench to install the feedscrew, lift the feedscrew slightly while pushing it in.

POWER LOCKED

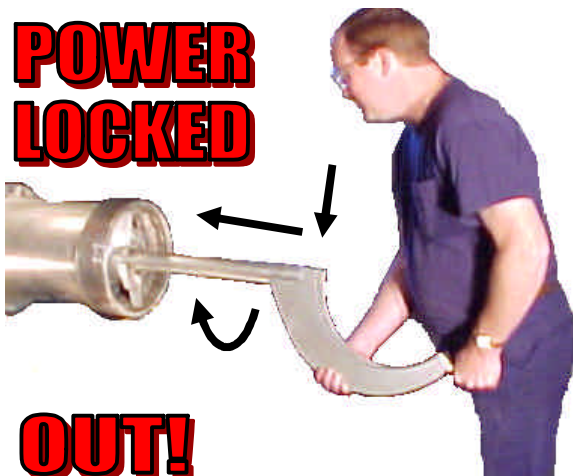

OUT!

If the feedscrew does not slide up on the spline, it may be necessary to push down and in, while turning the feedscrew slightly to engage the drive spline. B drives engage easier than the older A drives. Never reach into the hopper to engage the drive spline. The feedscrew will jump in another inch when it is seated on the spline. Check the head space!

NOTE: THE FEEDSCREW SHOULD NEVER RUB THE HEAD

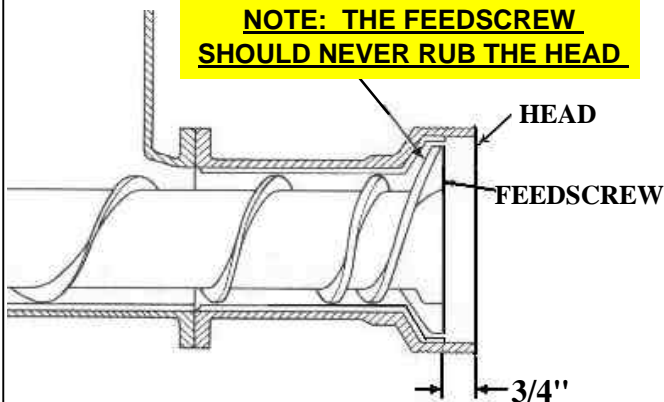

The head space should be checked on a weekly basis. The head space is 3/4" on all DGI grinder units. This should be done with the excluder seal removed. Spacers should be added if the measurement is more than 3/4". Spacers should be removed if less than 3/4".

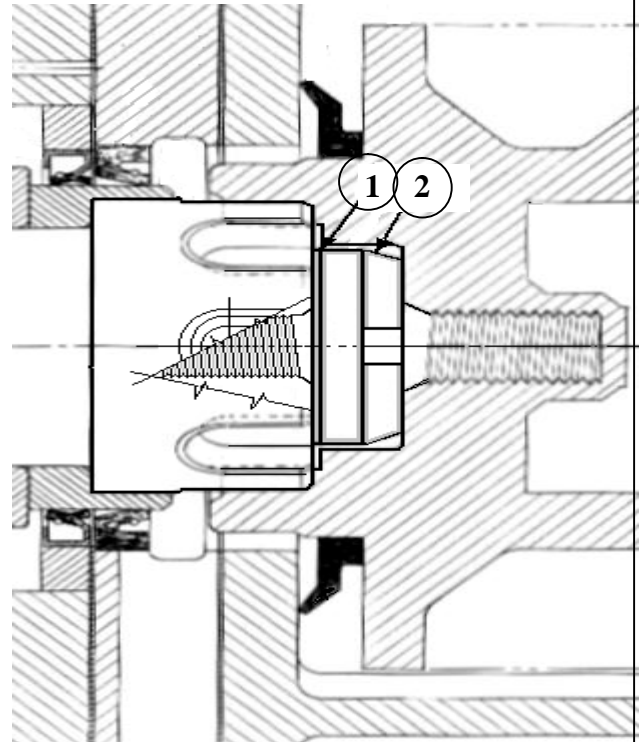

HEAD SPACE ADJUSTMENT. A TYPE.

Item 1 is our Adjustment Washer Part Number 1615 (1/16" thick) and/or Adjustment Washer Part Number 1614 (1/8" thick). These are used with the Thrust Screw Part Number 1468 or the Adjustment Bolt Part Number 0607 (Item 2). Add or subtract washers to obtain the 3/4" head space dimension.

Note: In the above illustration the Thrust Screw is shown mounted in the hole in the A type mainshaft. If the threads in the main shaft fail, or a thrust screw or adjustment bolt breaks off and removal is not possible, threads have been provided in the feedscrew hole. Obviously, the Thrust Screw or Adjustment Bolt should be installed in the main shaft or the feedscrew, not both.

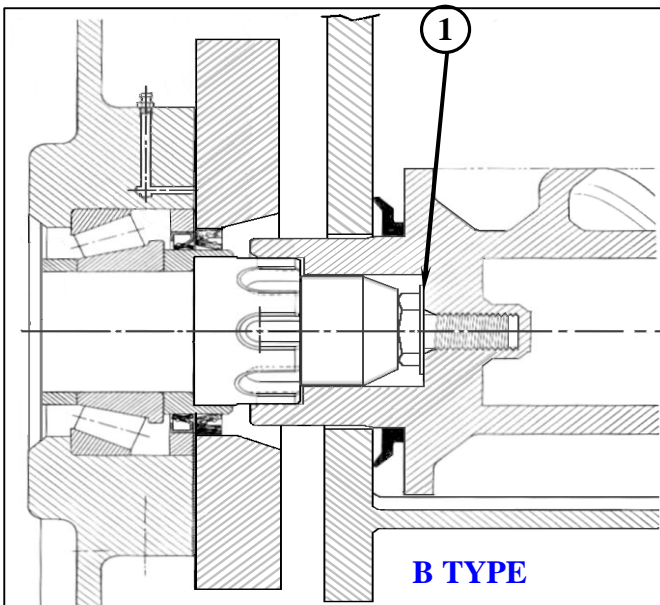

**HEAD SPACE ADJUSTMENT,
B TYPE.**

Item 1 is our Adjustment Washer Part Number 1615 (1/16" thick) or Adjustment Washer Part Number 1614 (1/8" thick). These are used with a 1" 8 TPI Grade 8 bolt, 1-1/4" long (Part Number 0606). Add or subtract washers to obtain the 3/4" head space dimension.

NOTE: This step is necessary when changing feedscrews, heads, hoppers, or if the gearbox has been rebuilt. Failure to set the proper head space may result in serious damage to the unit. If the feedscrew is allowed to rub the head, metal particles may contaminate your finished product!

When the Head Space has been adjusted, remove the feedscrew so that the Unit can be assembled for operation.



KNOW YOUR MACHINE

READ OPERATING & SERVICE INSTRUCTIONS BEFORE INSTALLING PARTS OR SERVICING MACHINE IN ANY MANNER. BE SURE THAT MACHINE IS STOPPED AND ALL POWER IS OFF AND LOCKED OUT. THIS INCLUDES ELECTRICAL, HYDRAULIC, AIR, STEAM, ETC. FAILURE TO FOLLOW THIS RULE, OR TO PRACTICE SAFE OPERATING PROCEDURES CAN RESULT IN SEVERE PHYSICAL INJURY.

UNIT ASSEMBLY:

Please study all the grinder parts shown on the exploded view before you attempt to assemble the grinder unit. (The exploded view follows the Maintenance section.)

(These instructions assume that the grinder unit has not been disassembled any further than the instructions have already given.)

Step 1. Inspect the excluder seal. It should be clean and free of nicks, cracks, or tears. If the excluder seal is damaged it should be replaced.

It may be necessary to tap the excluder seal in position. Use a rounded punch and soft taps to help it in its proper position. Do not use a screw driver or other pointed objects. Push only around the center of the seal, do not push on the soft lip. Apply force at the hub of the seal, as shown. The lip of the excluder seal faces out, and contacts the hopper flange.

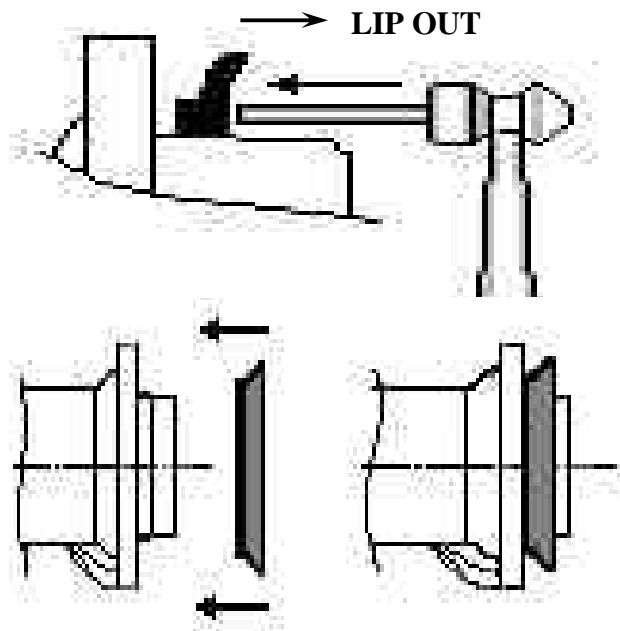

Step 2. Apply a small amount of edible grease, vegetable shortening, tallow, lard, chicken fat, bear fat, or some other lubricant to the face of the seal. (Check with your Quality Control Dept. and your USDA representative for approved materials.)

Step 3. Apply a liberal amount of this same lubricant to the female drive spline teeth!

Step 4. INSTALL FEEDSCREW.

Using the Model FSP2005 feedscrew puller, or other device, install the feedscrew into the grinder unit. Do not attempt to install the feedscrew by hand, or by yourself. You will notice that when using the FSP2005 the feedscrew usually engages on the drive spline with little effort. If you are not using the FSP2005 it will be necessary to use the handle end of the ring wrench.

POWER LOCKED OUT!

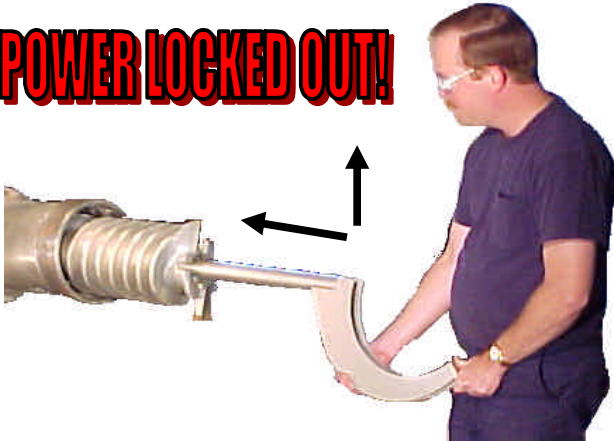

When using the ring wrench to install the feedscrew, lift the feedscrew slightly while pushing it in.

POWER LOCKED OUT!



If the feedscrew does not slide up on the spline, it may be necessary to push down, in, while turning the feedscrew slightly to engage the drive spline. B drives engage much easier than the older A drives. The feedscrew will jump in another inch when it is seated on the spline.

Step 5. INSTALL CENTERING PIN.

Inspect the pin to make sure it is clean and free of nicks and burrs. Replace the pin when it shows wear grooves, checks, or is worn.



Place the pin key into the slot in the centering pin.

POWER LOCKED OUT!



Insert the pin in the pin hole of the feedscrew. As you push the pin in, line up the key with the keyway. The pin bottoms out in the hole in the feedscrew. The pin should slip in by hand! If it does not check the pin hole for nicks and foreign material.

POWER LOCKED OUT!



Step 6. INSTALL SPRINGS.

The Belleville springs are installed with one spring facing down, and the second facing up toward the back surface of the knifeholder, which will be installed next.

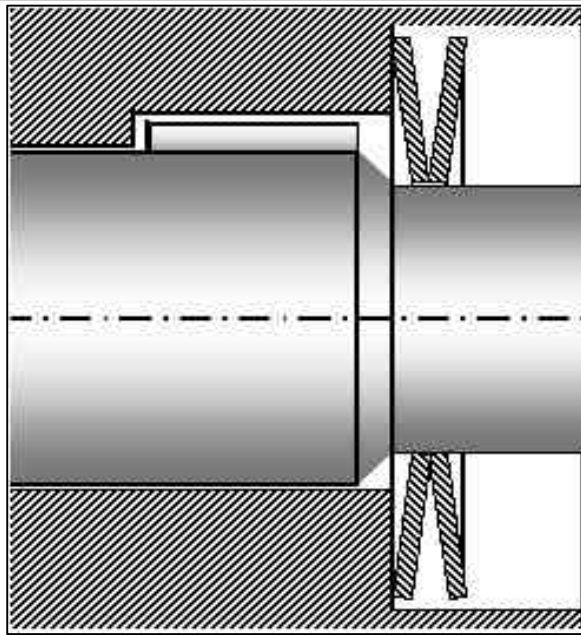

In the above illustration notice that the face at the outer diameter of the first spring is touching the counter bore in the face of the feedscrew. The second spring is opposite and will contact the knife in the same fashion. Do not stack the springs one on top of the other like dishes, this doubles the spring force and will provide too much force against the knife inserts. Do not use more than two springs.

The Belleville springs provide a better power curve than coil type springs, and are designed to provide near uniform power over the life of the knife inserts.

On heavy duty grinders a pin collar is installed prior to the Belleville springs.

Step 7. REPLACE INSERTS

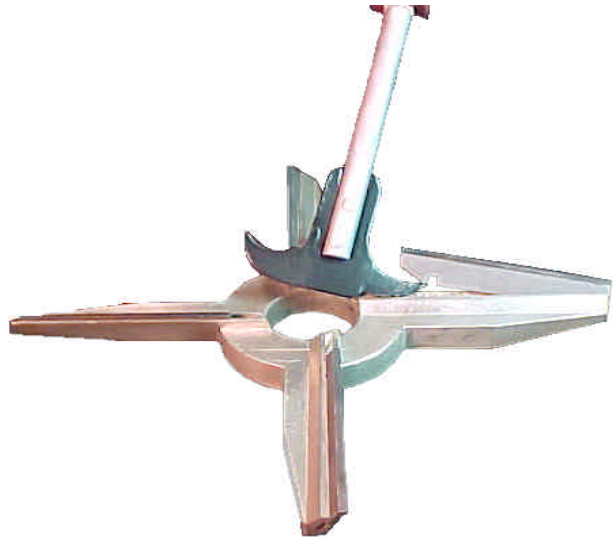

Inserting the pointed end of our insert remover into the slot of the knifeholder provides a quick and easy way to remove the knife inserts. Removing them in this manner minimizes damage to the insert locating pins found in the bottom of the insert slots in the knifeholder. We recommend starting with fresh inserts at every plate change! This includes when turning the plate around.

Step 8. INSTALL KNIFEHOLDER.

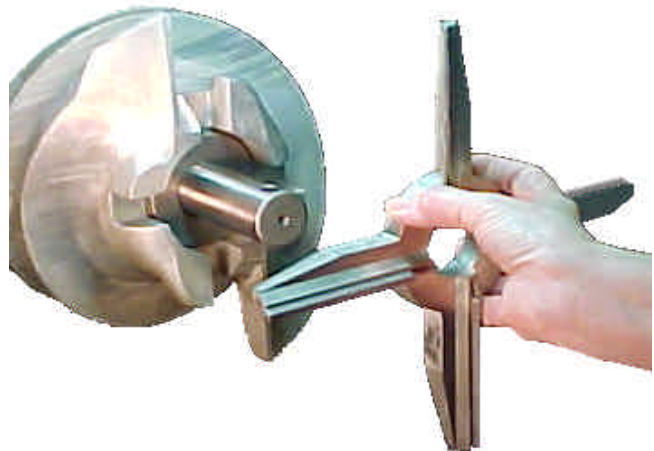

POWER LOCKED OUT!

The knifeholder with fresh inserts simply slides over the pin and contacts the spring. The inserts face out! Be careful, the inserts are sharp.

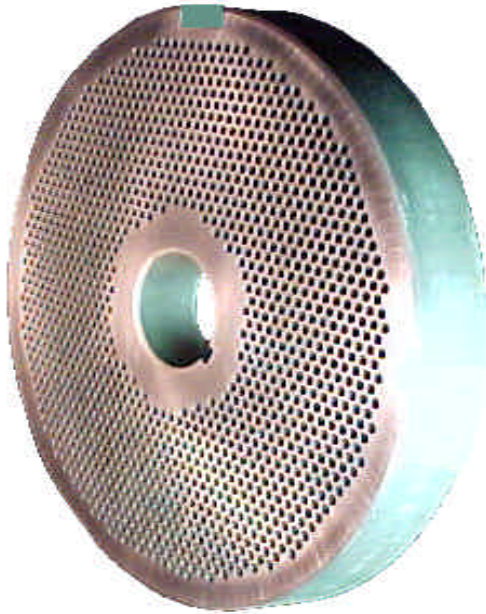

Step 9. INSPECT THE ORIFICE PLATE:
 (This inspection is performed with the plate out of the machine.)

Sharp plates may cut you, be careful!

Inspect the plate before each use.

Inspect the edge of the holes, they should form sharp corners.

The plate should be clean.

Check for discolored plates, do not use a plate with a deep blue coloring between the holes.

Check for cracks, especially between the holes. If cracks are present, do not use the plate.

Check for grooves, broken holes, and any other defect.

Do not use defective orifice plates.

We recommend that a fresh plate surface should be used every 8 hours of operation. Operations that run empty or with hard to grind materials may have to change plate surfaces every 4 hours.

Grinder Plates should be sharpened with a vertical type surface grinder, typically called a "Blanchard Type". With this type of surface grinder the plate should be placed directly over the center of the table. We do not recommend sharpening the plates when they are placed out on the table, not directly over the center of the table.

We recommend using our grinding wheels to sharpen the plate. These specialized grinding wheels produce the correct surface finish to provide clean, cool, cutting. Plates that are not sharpened correctly will not grind even the softest of meats. The plates must be flooded with coolant when they are ground. The horsepower rating of your surface grinder will determine feed rate. The plate should be sharpened enough to restore the edge of the hole, and remove any discoloration from running empty (see Maintenance Instructions, Grinder Plates). Nicks and gouges should be ground out.

The plates should be ground perfectly flat, or slightly concave, .002 per side max.

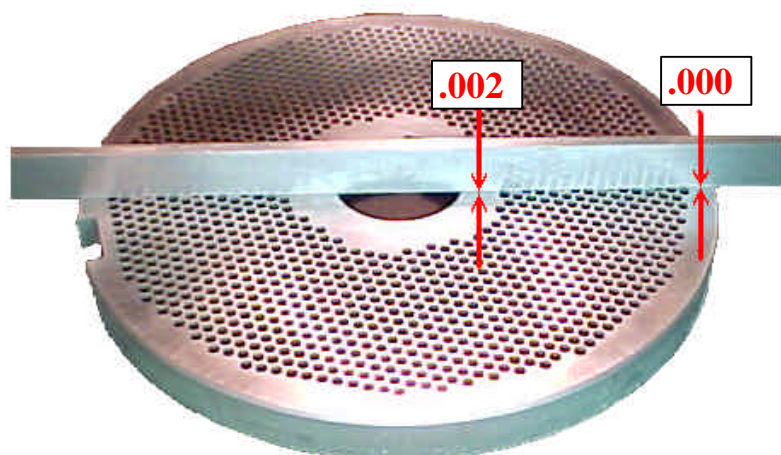
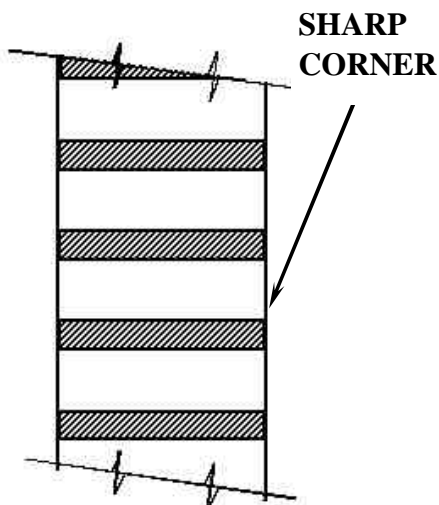

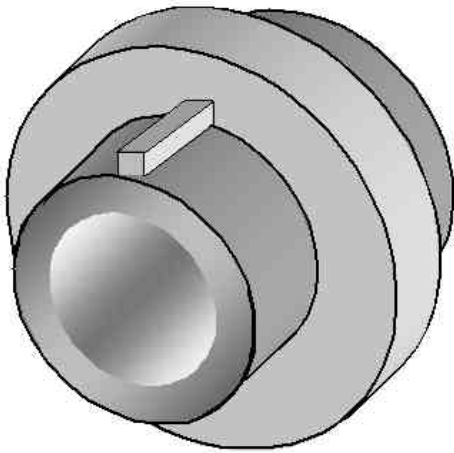

Step 10. INSPECT THE PLATE BUSHING.

The plate bushing should be clean, and free of nicks and burrs. Inspect the inside diameter, it is common to show wear because the bushing supports the weight of the feedscrew. Replace the bushing when there is .035 wear, or the inside diameter measures 1.540.

Apply a generous portion of edible grease, vegetable shortening, tallow, lard, chicken fat, or some other lubricant to the inside diameter of the bushing. (Check with your Quality Control Dept. and your USDA representative for approved materials.)

Step 11. INSTALL PLATE BUSHING.

Install plate bushing into orifice plate. Then lubricate the inside surface of the grinder plate. (The side that will be in contact with the knife inserts).

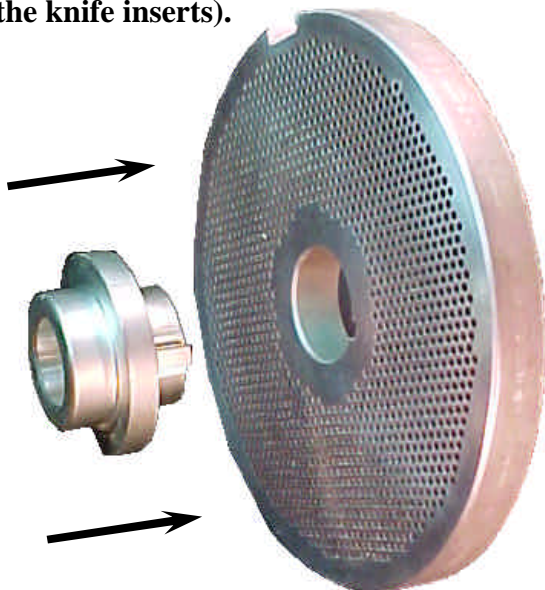

Step 12. INSTALL PLATE AND BUSHING INTO GRINDER UNIT.

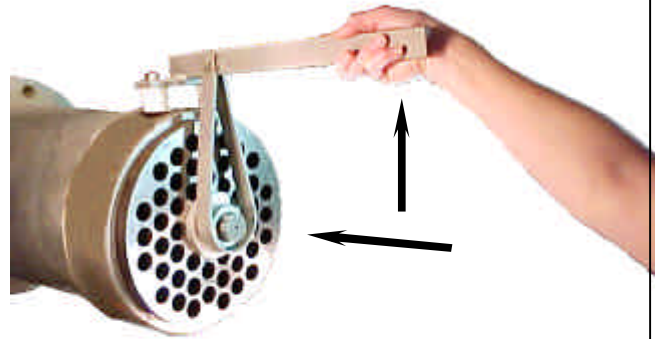

POWER LOCKED OUT!

Slide the orifice plate with the plate bushing installed over the end of the grinder pin. Lift the end of the plate lifter handle and push the plate into the grinder unit.

Step 13. INSPECT THE HEAD THREADS.

After the plate has been installed we recommend inspecting the head threads. The threads must be perfectly clean, and free of any nicks or burrs. If there are nicks or burrs they must be removed or the ring and head may lock together. When the threads are clean, lubricate the threads with a small amount of edible grease. Do not use mineral oil!

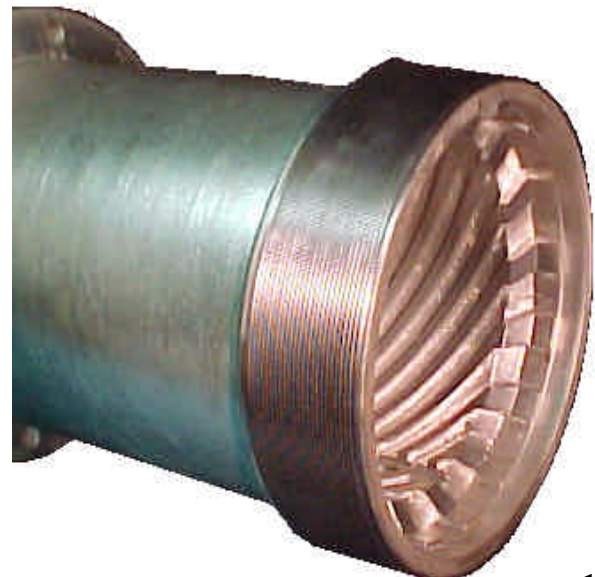

Step 14. INSPECT THE RING

The threads of the ring should be inspected before the ring is assembled on the head. The threads must be perfectly clean, and free of any nicks or burrs. If there are nicks or burrs they must be removed or the ring and head may lock together. The plate support and the bushing support areas should also be free of nicks and burrs.

The ring can weigh up to 65 pounds, if this is more than you can comfortably lift, get help. If you have a ring remover, use it. Be careful that you do not bang the ring against the center pin or other object. If you think that you have cross threaded the ring, repeat Step 14.

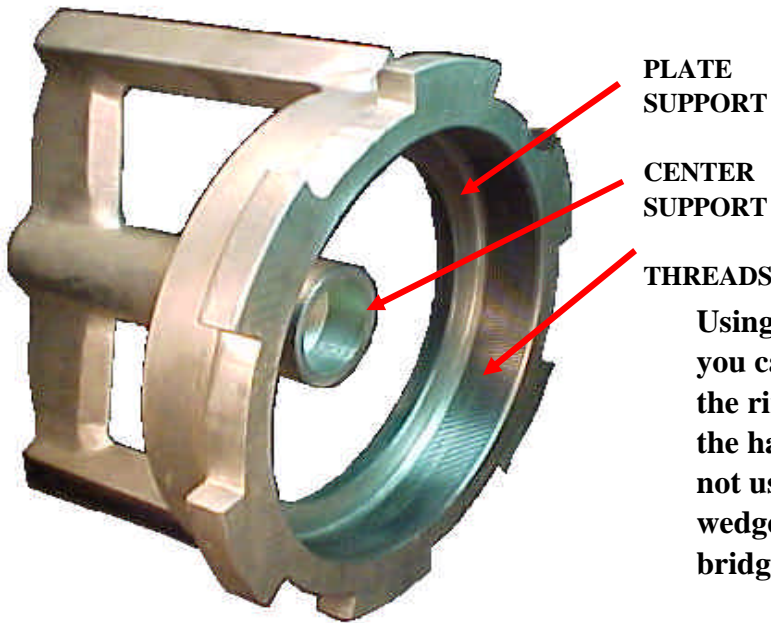

The threads are right handed, so turning the ring clockwise screws it on the head. When you can not turn it further use the ring wrench to tighten it.

Using the ring wrench tighten the ring until you can tighten it no further. Do not slap the ring wrench, rather just push down on the handle. Use the ring wrench only! Do not use a pipe extension! Do not use a pipe wedged between the center support and the bridge support.

Step 15. INSTALL RING.

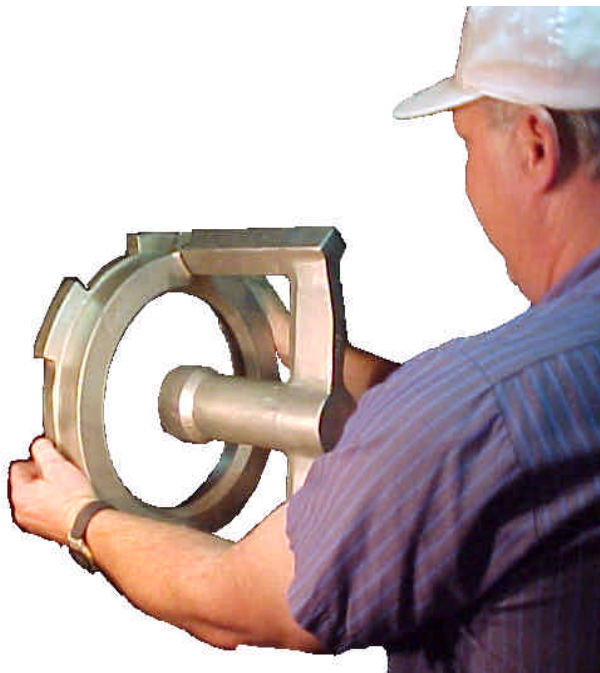

When the ring is tightened, back it off 1/8 to 1/4 turn for fine grinding, 1/2 turn for coarse grinding.





Step 16. INSTALL THE PLATE GUARD. Slide the rods of the plate guard into the clamps mounted to the head and tighten the wings nuts.

POWER LOCKED OUT!

PRE-OPERATING INSTRUCTIONS.

Before operating, make sure that nothing has fallen into the grinder during the assembly process. This should be done while the power is still locked out. If the hopper is empty, proceed. If there is something in the hopper do not reach inside the hopper with your hand, use a long hook, or some other tool to extract the object.

When the grinder has been fully assembled, checked to make sure nothing is in the hopper, all operators are out of the way, and all guards are in place, the power can be unlocked.

DO NOT TURN THE GRINDER ON YET!

OPERATING INSTRUCTIONS.

The grinder unit should never be left unattended while running. If you have to be away from your work station, turn the grinder off. If for any reason the grinder has to be taken apart, the **POWER SHOULD BE LOCKED OUT!** We recommend a strict policy that states *"Touching the grinder while the power is not locked out will result in immediate termination!"* This includes a plate change, or even removing the plate guard.

The grinder unit should be turned on only when product begins to fall into the grinder hopper. Do not turn the grinder on, then drive around the plant looking for a combo of meat to grind. When the product is ready to be ground, and has traveled up the screw conveyor, or the dumper has been raised, turn the grinder on just before product falls into the grinder hopper.

The grinder should be turned off when product stops coming out of the grinder. If the grinder is left running without product, the knife inserts will rapidly dull and generate undesirable heat. The heat generated by the inserts will damage the plate. The pin and bushing rely on the product to supply lubrication and cooling. If the grinder is left running without product, the pin and bushing will also heat up and in some instances they weld together.

Do not grind products that were not intended for this machine. All grinder units are designed for a specific purpose. A fresh meat pre grinder may not perform satisfactory on regrind, and may not be able to grind frozen meat at all.

If you are unsure of what product this grinder was designed for, please call Dixie Grinders Inc. at (800) 745-0586 or (256) 582-0477.

OPERATING INSTRUCTIONS continued.
The hopper guard is a guard, not a large capacity chute or storage bin. Large pieces of fresh meat do not bridge as easily as pre-ground material, but the grinder cuts the cleanest when only the feedscrew is covered with product.

Because of the aggressive nature of this type of meat grinder, excessive amounts of product in the grinder hopper will roll. The feedscrews are made this aggressive to insure that the head is 100% full, thus maximum capacity can be achieved. The draw back to this design is that over feeding in the hopper will result in damage to the finished product. Feedscrew designs exist with lesser pitches in the hopper to reduce the rolling. We also have special hopper designs that all but eliminate product rolling.

If the grinder becomes bridged, do not attempt to free the bridge while the grinder is running. Shut the grinder off, and from a safe distance using a long fork or hook free the bridge. **DO NOT FOR ANY REASON ATTEMPT TO BREAK A BRIDGE BY HAND.**

If an object falls into the grinder unit that requires manual removal, the grinder must be shut off then the

POWER LOCKED OUT!

With the key to the lock in your teeth you may attempt to remove the foreign item. If you are unsure of how to lock out this machine, or you do not have a lock, see your supervisor, plant safety officer, or the plant manager and get one. **THIS MACHINE MUST NEVER BE TOUCHED WITH THE POWER LIVE!** This machine does not know the difference between humans, beef, pork, or fowl, so be careful.

Never operate a grinder unit while under the influence of alcohol or drugs.

Do not place your hands under the plate guard for any reason.

Do not shut the grinder off when full of product unless it is an emergency. If the grinder is full of frozen product you may damage the unit by attempting to start it when full.

Never turn the grinder on to push the plate out when taking the grinder apart! The grinder must have the power locked out and it must stay locked out during the entire disassembly process.



KNOW YOUR MACHINE

READ OPERATING & SERVICE INSTRUCTIONS BEFORE INSTALLING PARTS OR SERVICING MACHINE IN ANY MANNER, BE SURE THAT MACHINE IS STOPPED AND ALL POWER IS OFF AND LOCKED OUT. THIS INCLUDES ELECTRICAL, HYDRAULIC, AIR, STEAM, ETC. FAILURE TO FOLLOW THIS RULE, OR TO PRACTICE SAFE OPERATING PROCEDURES CAN RESULT IN SEVERE PHYSICAL INJURY.

MAINTENANCE INSTRUCTIONS: GRINDER RING.

The grinder ring needs little maintenance other than thread inspection. The center support should contact the slip in bushing at the same time that it contacts the plate. If there is any clearance between the plate bushing and the center support after the ring has been tightened first inspect the plate for flatness, see page 15. If the plates are flat, or within .002 per side of being flat, send the ring in for rebuilding. If foreign material causes a plate to break, inspect the ring before use. The center support sets back .500 +.000/ -.002

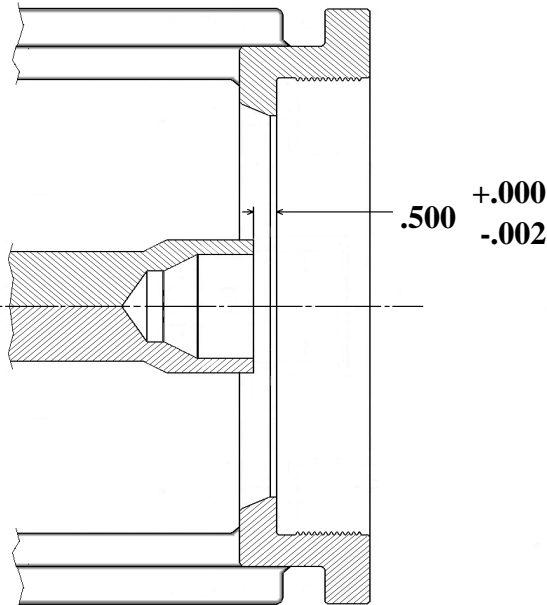
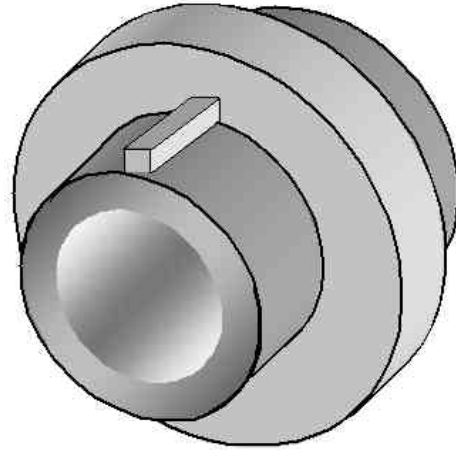

PLATE BUSHING.

The plate bushing supports the weight and the side load of the feedscrew. Being a plain bearing it relies on the product for lubrication and cooling. The bushing is mild steel and carburized. The hardness is only .040 deep, and some of this is used during the honing after the bushing has been hardened. Therefore we recommend to discard the bushing when it measures 1.540 ID. Typical wear is very even. Checking or grooves indicate that the machine is run empty often. Normal life is about one month.

Failure to change the pin and bushing shortens the life of the feedscrew and the head. When the pin and bushing become worn they allow the feedscrew to contact the head. This results in rapid wear to the feedscrew and head, and can even lead to metal in the finished product.



GRINDER PLATES.

The orifice plate is probably the most important single piece of a meat grinder.

Dixie Grinders Inc. sells only "PREMIUM" type tool steel plates. Extensive testing has shown time and time again that our selection of tool steel performs the best over the entire range of products ground. Our special heat treatment process, that includes a soak at - 300°F for two hours gives our plates the toughness that we have found is required. Other steels may stay sharper, but when it breaks into ten pieces its sharpness is no longer an advantage.

We have studied hole plate configuration and we have improved almost every plate hole pattern. We also offer a series of maximum capacity type plates. These plates have many more holes than a normal plate, but there is some reduction in strength.

These plates allow our customers an increase of up to 100 pounds per minute in some applications. When combined with the "Thin Plate" series it produces a plate that can really get the job done. We offer these plates in our BCA-2 series of plates, and the old 7 peanut slot plates, the 2437 and 2442 series of plates. For our pet food customers, we offer this technology in the 2114 and 2118 series of plates.

If you are breaking plates from tramp metal, and are using a thin plate, perhaps a full thickness plate may be the answer. A standard hole pattern plate would be even stronger.

If your plates are turning blue, the operators are running the grinder empty. The blue color indicates temperatures up to 600°! This is above the draw temperature of this steel, and unless the heat affected zone is removed this plate will crack. Under careful examination you may be able to determine how deep the discoloration is by looking down the holes. We recommend removing this layer, plus .030! Plates with cracking between the holes can be attributed to this condition 99% of the time.

The most important feature, however, is sharpness. Most people think that a grinder plate should shine like a mirror, the fact is that a certain amount of roughness is required. The roughness of the plate is what keeps the the inserts sharp. We supply a specially manufactured grinding wheel that is 36 grit, rather than the 60 or 80 that other companies sell. The grains themselves should be soft and what is called friable, that is when dull, it should leave the wheel. If you buy a good knife, you sharpen it with a very soft stone. These plates are harder and tougher than a knife blade, therefore it only makes sense to sharpen it with a soft stone. Dress the wheel before sharpening each plate. Do not let the wheel spark out, when the plate is sharp, get the wheel off the plate!

A majority of all service calls eventually point to the customers real problem, dull plates. Next to plate sharpness, plate flatness is important. Grinder plates should be ground flat, or slightly concave. Using a precision straight edge and feeler gauges the amount of concave can be determined (see page 15). Plates that are ground convex will not work properly. The knife inserts will not seat at the outer edges of the plate, and the product will not be cut cleanly.

The plates also must be uniform in thickness. If the bearings in the table of your surface grinder are worn, it is possible that the plates will not be uniform. Using a micrometer, measure around the outside edge of the plate, there should be less than .0005 variation. Measure around the inside diameter also, this should also show less than .0005 variation. If the measurements are consistently less at the inside diameter than at the outside diameter you also may assume that the plate is concave, and if thicker it may be convex. It is rare that a plate would be convex on one side and concave on the other, but measuring with a ground straight edge and feeler gauges is the best test for flatness.

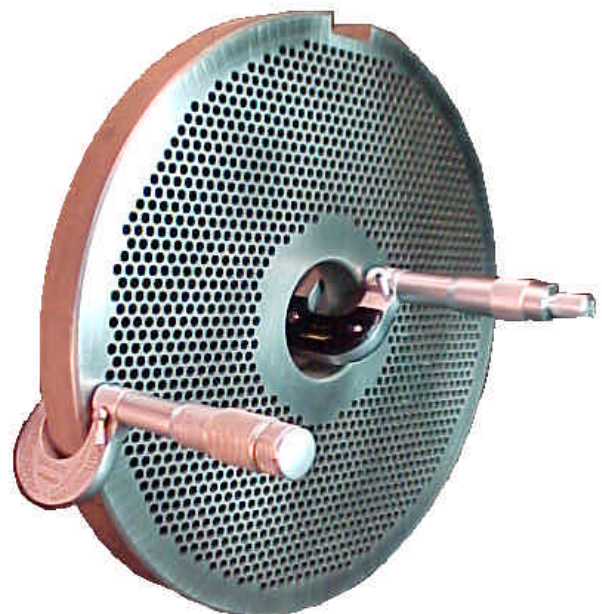

Examine the grinder plate for cracks before each sharpening. If tramp metal has been ground, examine the plate very carefully. A plate that is free of cracks will have a distinctive ring if struck with a small metal rod. Strike the edge of the plate on the 30° chamfer. Do not use a mallet to ring the plate, a gentle tap is sufficient. Plates that are cracked will not ring well, and often you will simply hear a thud.

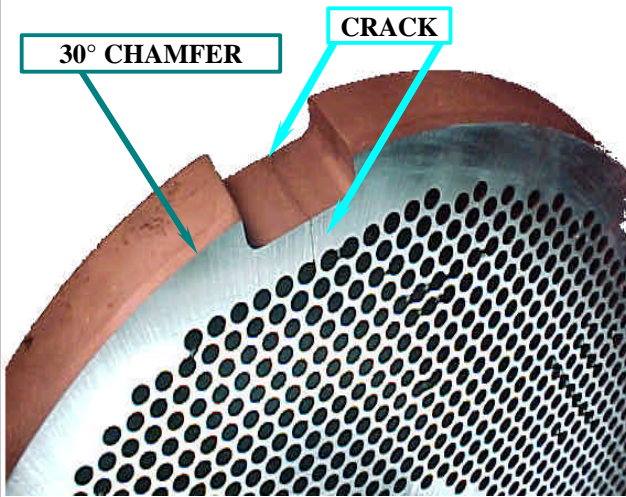

Notice the tramp metal stuck in one of the holes. The tramp metal must be removed.

Note the gouges that extend from hole to hole. These gouges must be ground out.

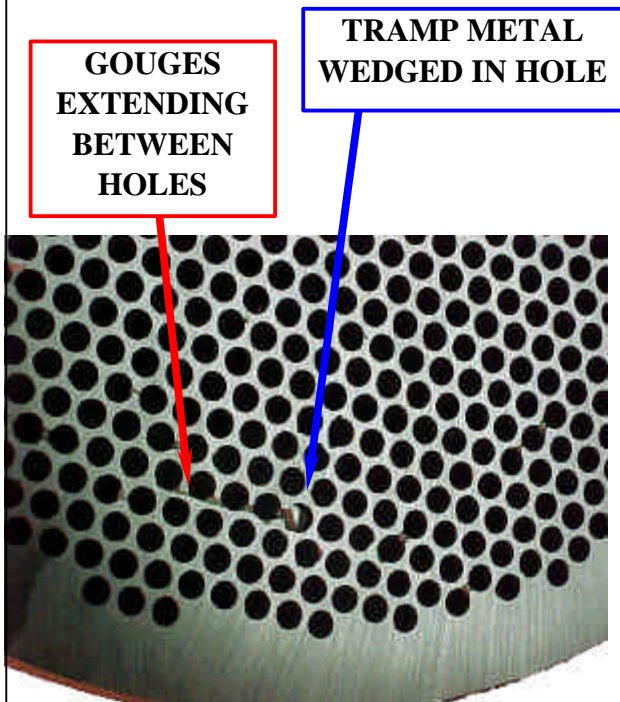

When grinding plates, **do not** place the plate at the outer edge of the surface grinder table.



Rather, place the plate over the center of the surface grinder table, like this!



The sharpened grinder plate should have fine lines extending from the outer edge, through the center of the plate, then back to the outer edge. In drafting terms the symbol would be

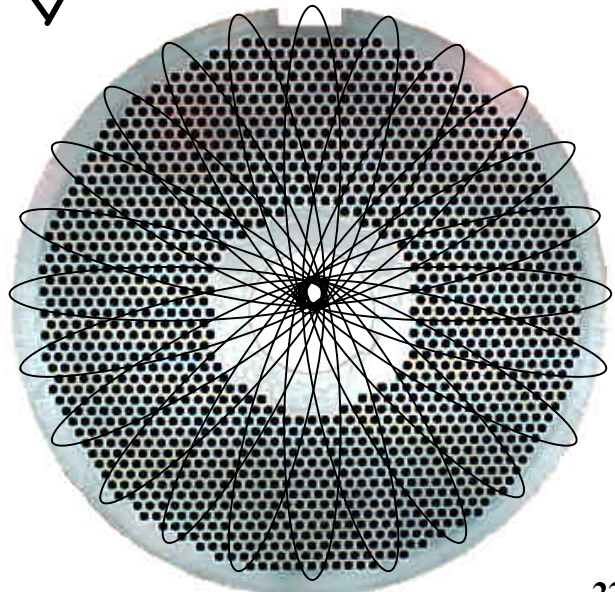
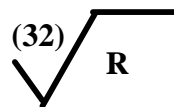

CENTERING PIN.

The pin must be removed daily for sanitation. The vent slot should be clean, and free of obstruction. The small diameter that the bushing runs on is the only place that wears. Some discoloration is permissible, but if this area turns blue, it is possible that the machine was run empty for an extended period of time. The damage from empty running cannot be repaired, and the pin should be replaced.

Under normal conditions the pin usually lasts about three months, or three bushings. If some roughness is noticed this can be smoothed out with an external grinder, or very fine sand paper in a lathe. A rough surface on the pin will wear the bushings out at an unexceptable rate.

The pin should be replaced when the diameter has .030 wear, or it measures 1.470 .

SPRINGS.

The washer springs last a very long time. They are designed to last for about five million cycles, so it is doubtfull they will ever wear out. When placed together as shown, the gap at the outside should measure 3/16".

2578 SPRINGS SHOWN.

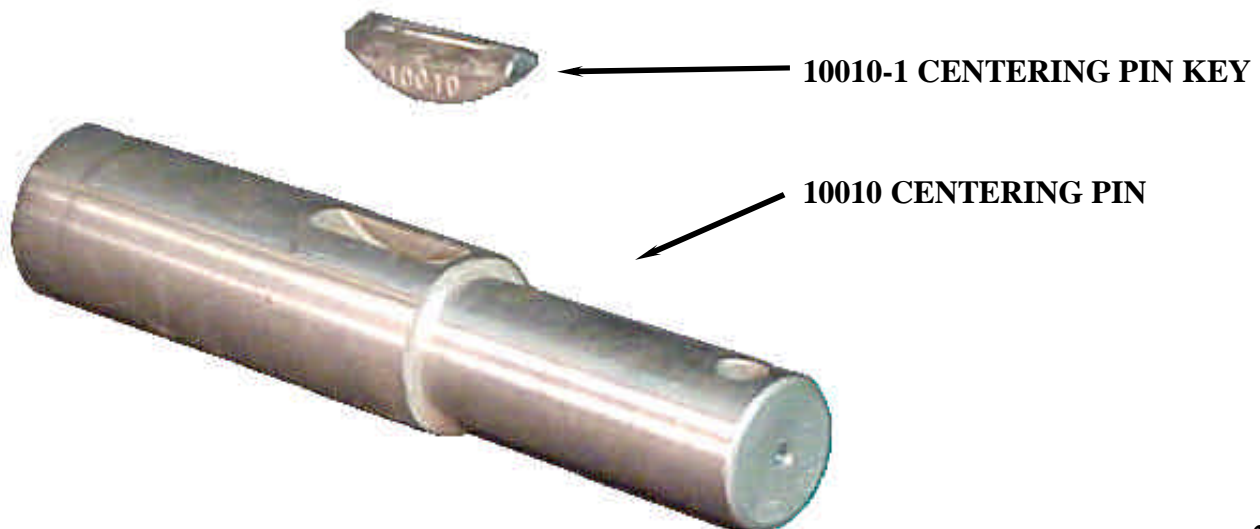
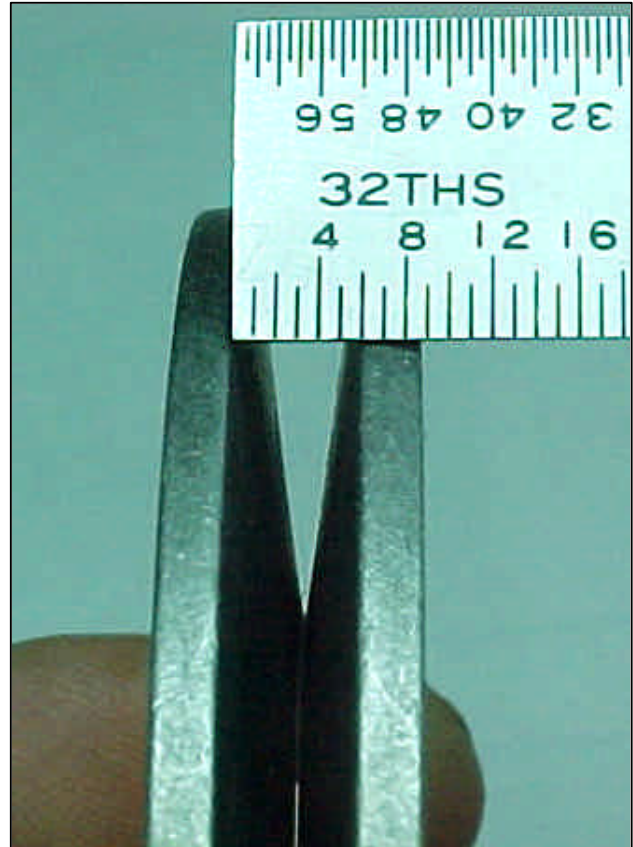

KNIFEHOLDERS.

As explained on page 14, inserting the pointed end of our insert remover into the slot of the knifeholder provides a quick and easy way to remove the knife inserts.

Removing them in this manner minimizes damage to the insert locating pins found in the bottom of the insert slots in the knifeholder. We recommend starting with fresh inserts at every plate change! This includes when turning the plate around.

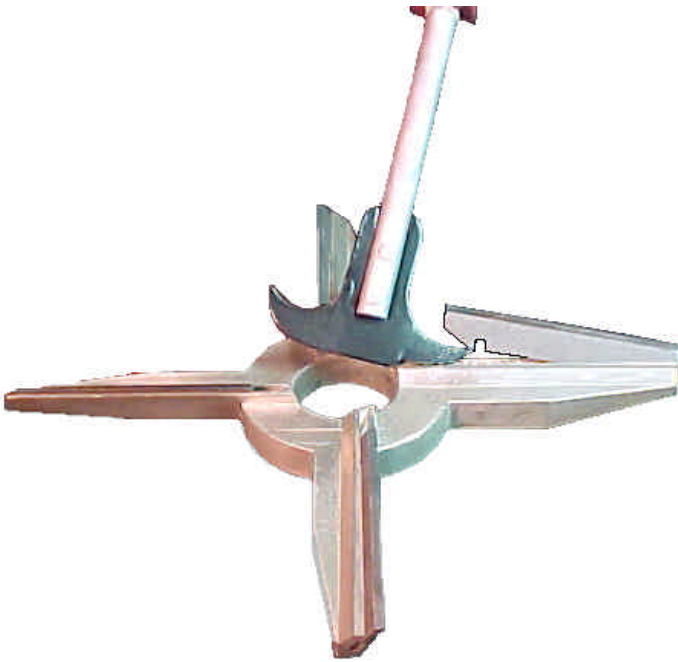

With the inserts out, inspect the slots. Every knifeholder has a pin that lines up with a notch in the knife insert. If the inserts are removed incorrectly these pins can be broken. Send your knifeholder with broken pins to Dixie Grinders Inc. for repair.

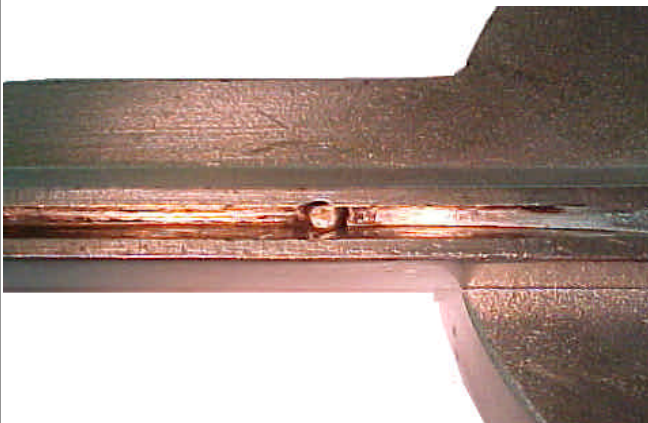

Inspect the knifeholder arms. When small pieces of tramp metal are ground, often the tips of the knifeholder become peened shut. With a small file, or burr grinder, these can be opened up. Larger pieces of metal may bend the arms clockwise at the tips. Inspect the arms where they are connected to the hub of the knife, if there are any signs of cracking, throw the knife away immediately.

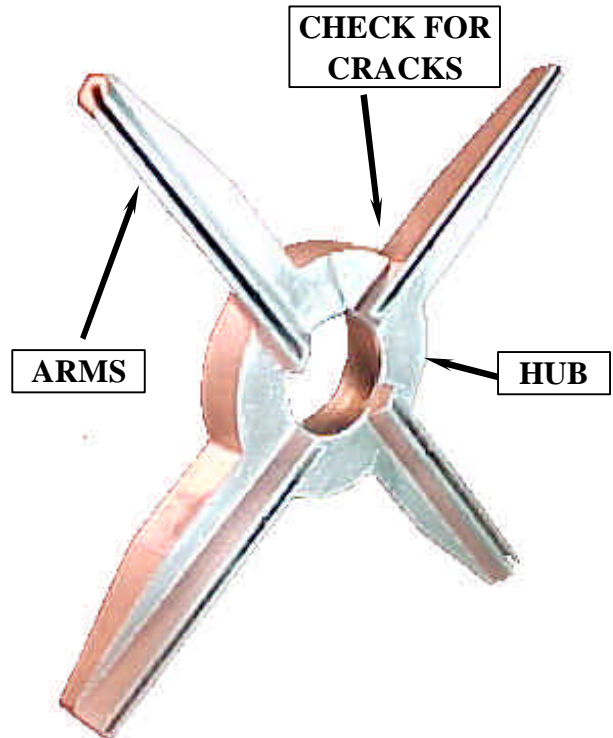

Examine the knife inserts. The edge of the insert should be free of burrs, Be careful, the inserts are sharp!



Line the notch of the insert up with the pin in the bottom of the slot of the knifeholder. If necessary tap the insert into position with a soft mallet, a soft rubber hammer, or a piece of pine. The inserts should fit snugly in the slots, but they should not have to be beat in. It may be necessary to open the slots slightly if they are too tight. Use a small flat file, or a cut-off wheel. Tap on the face of the knifeholder if they are too loose.

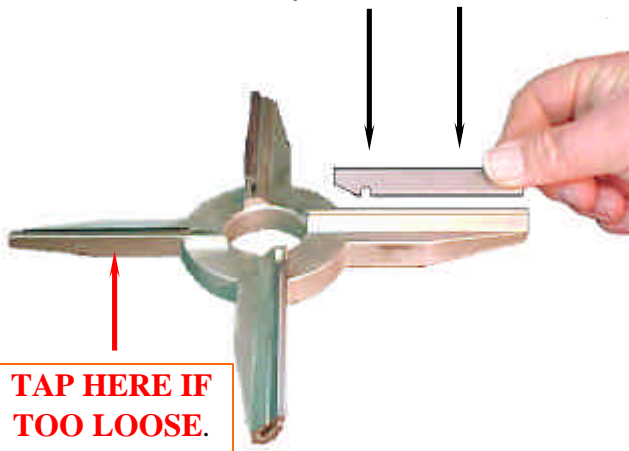

When the inserts have been properly installed turn the knifeholder over and check it for flatness. Use a properly sharpened plate, or other known "true flat" surface. If the knifeholder rocks, check to make sure all the blades have been properly seated. Check the bottom of the slots for obstructions. Make sure that the slot of the insert is lined up with the pin in the bottom of the slot.

A slight rock is permissible, a feeler gauge of .005 should not fit under the knife insert that is not touching the plate.

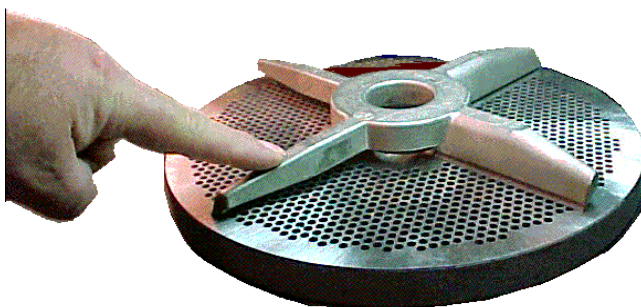

The combination of the insert slot angle and the angle that the inserts are ground provide that only the leading edge of the knife insert contacts the plate. This slight amount of clearance allows the insert to seat within a few revolutions of the grinder being turned on. The amount of material removed from the leading edge of the insert is not measurable, but it is advised that the first product that comes out of any meat grinder on start up is discarded.

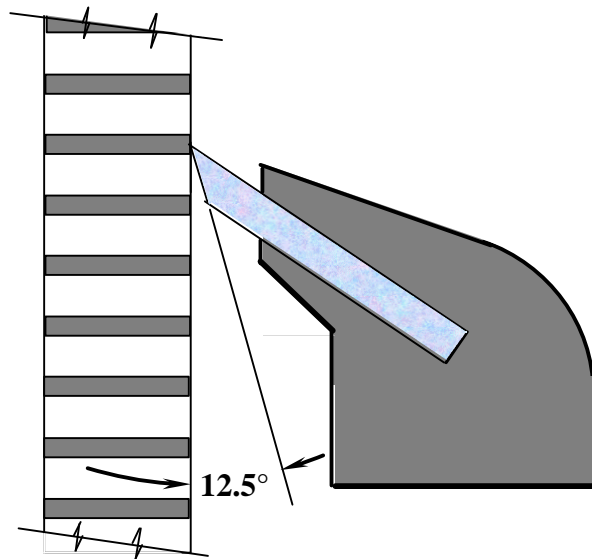

If inserts are not properly installed, excessive clearance will result.

Excessive clearance will keep the grinder unit from functioning properly, and in many cases it will not grind.

We recommend that maintenance, or a responsible person is entrusted with the function of changing inserts and sharpening the grinder plates. The success of your operation depends on it.

If you do not have the equipment to sharpen your plates, or you do not know if they are being sharpened properly, send them to Dixie Grinders Inc. (attention Service Department) and we will examine your plate, sharpen it properly, and return it to you promptly.

HEAD.

The heads have three different types of flutes. The bore flutes, the spin flutes, and the spin lugs.

The bore flutes are the spiral flutes that extends for about 15". The spin flutes are the flutes that are on the tapered section. The spin lugs are the flutes behind the plate.

Compare the picture of the new head to this worn head, the flutes should be sharp, not rounded.

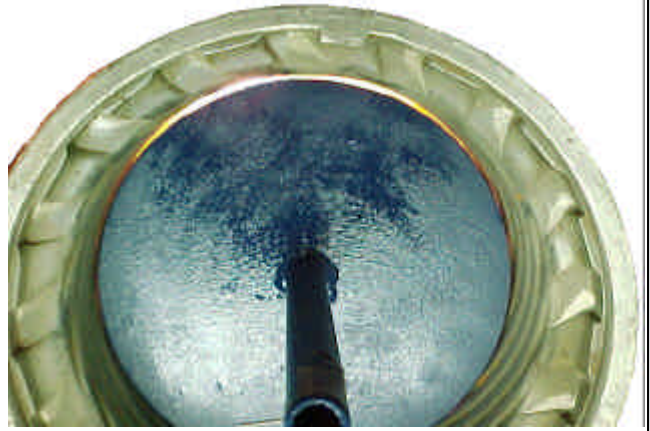

BORE
FLUTES

SPIN
FLUTES

SPIN
LUGS

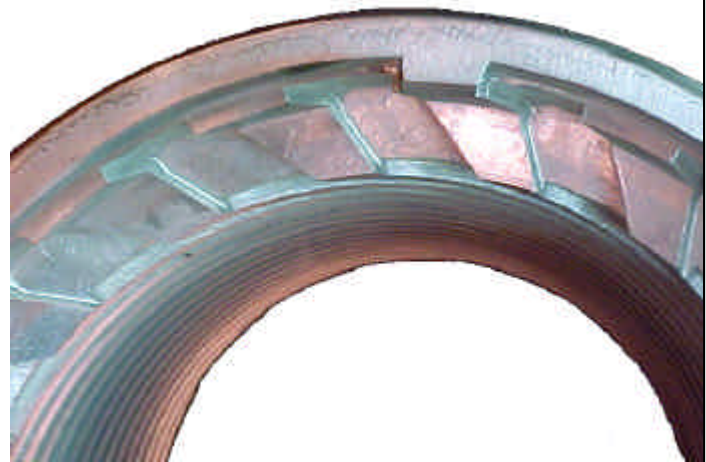

Notice the sharp corners on a new head.

The edges of the flutes should have a square corner. When they become rounded the head should be rebuilt.

Bore flute wear can be measured with our head guage.

When new the bore gauge fits tight. The wear limit depends on your application. For fine hole plates the head should be rebuilt when the clearance over the guage is 1/16" With large hole plates, 1/8" is the limit. Product definition suffers, and there is a loss of production when the wear is more than these amounts.

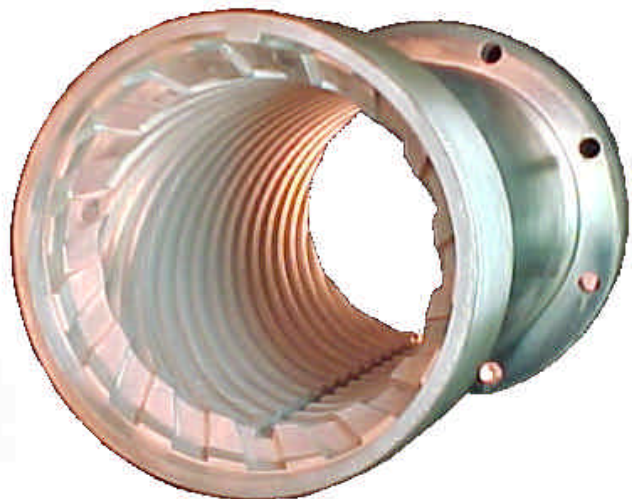

Shown is a new 11-9 spiral fluted head with 16 flutes. Pretty isn't it.

FEEDSCREW.

Foreign metal has obviously damaged this feedscrew. This type of damage makes this feedscrew unfit for use. Other than the tramp metal damage, this feedscrew has sufficient wear to make it unusable.

The outside diameter of the pressure flights are rounded. They should have a square edge. The front of the pressure flight should be flat. The outside diameter through the head section is rounded, and undersized. The knife drive lugs are bent (clockwise). This feedscrew is in serious need of rebuilding, and when rebuilt, it will look as good as new.

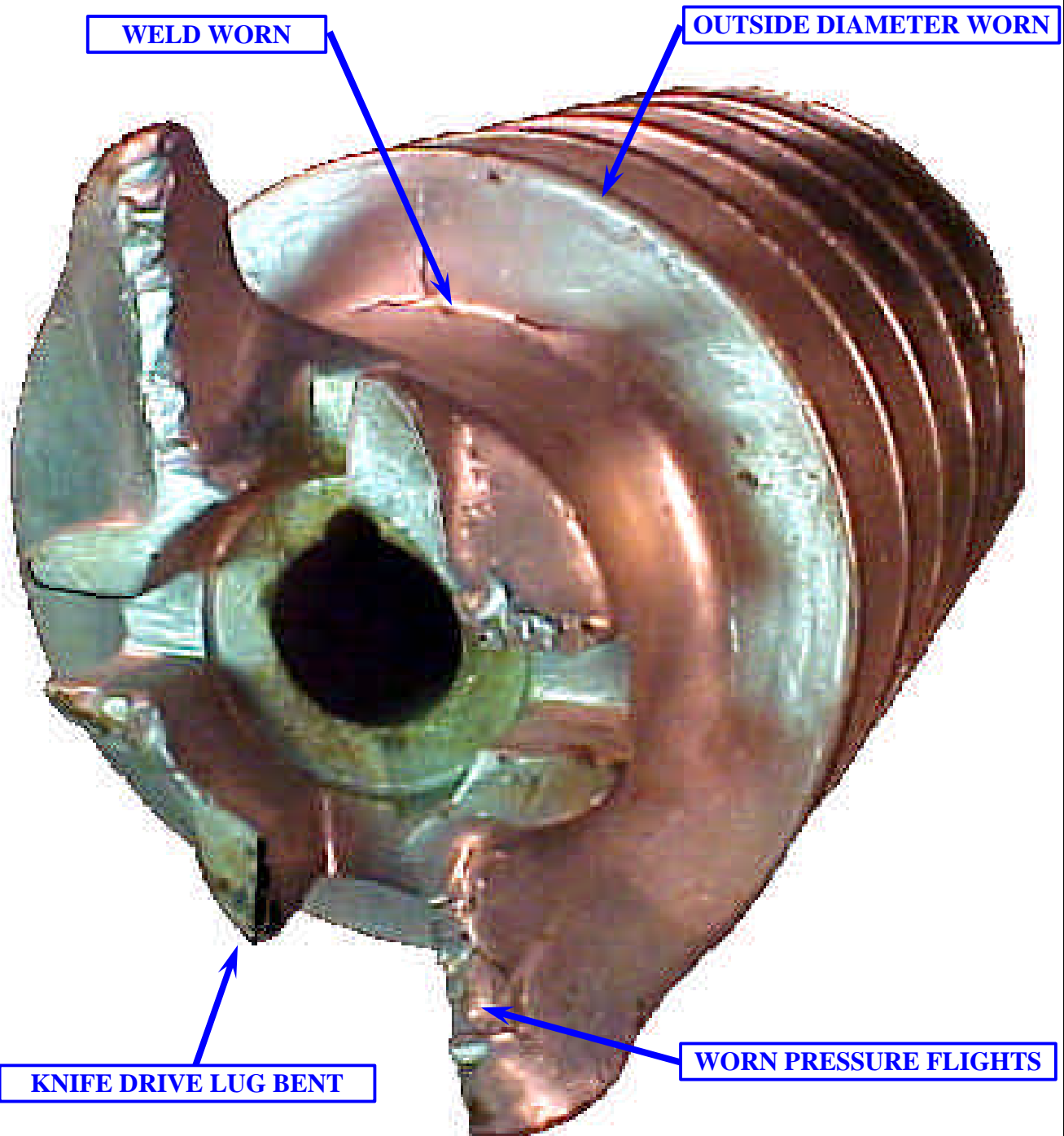

Examine the flights in the head section. Notice how the corners are rounded. The flighting should be replaced when it is worn down to 3/8" thick. Also notice the crack at the root of the shaft. There is so much wear of the weld that holds the flighting to the shaft that it is prone to cracking. A feedscrew with this amount of wear requires all new flighting. When we replace the flighting we machine the old flighting off, right down to the shaft. The flighting is replaced with new 1045 bar.

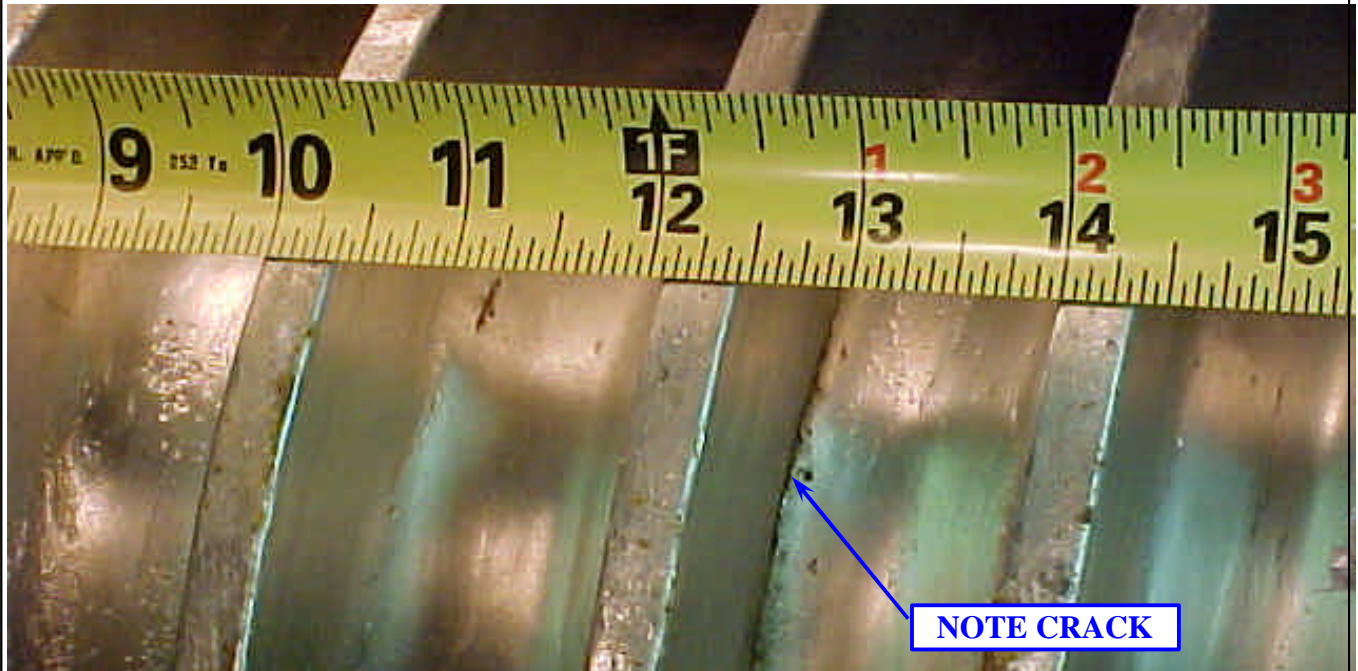

Examine the cupping. The cupping should have a sharp edge, so that it can aggressively capture the product being ground. When the cupping becomes dull the product is prone to rolling in the hopper.

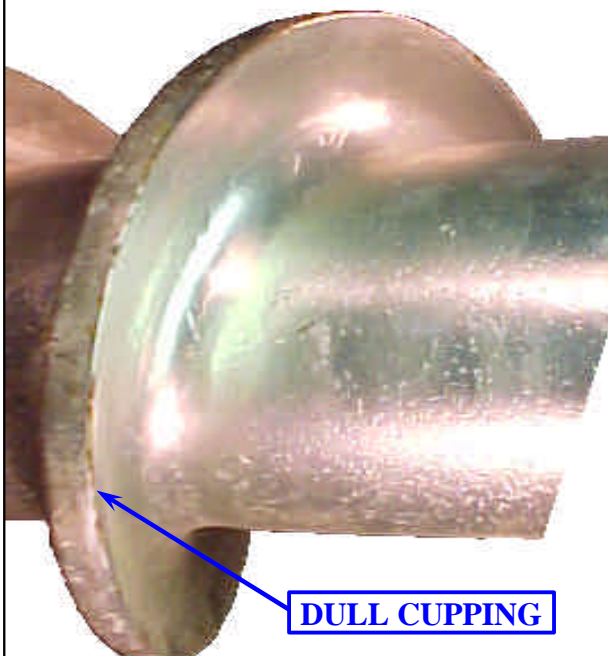

Examine the drive spline. The main shaft does not engage 100% of the drive spline, therefore the amount of wear of the drive spline can be determined by examining the base of the spline. Also note the wear on the adjustment bolt.

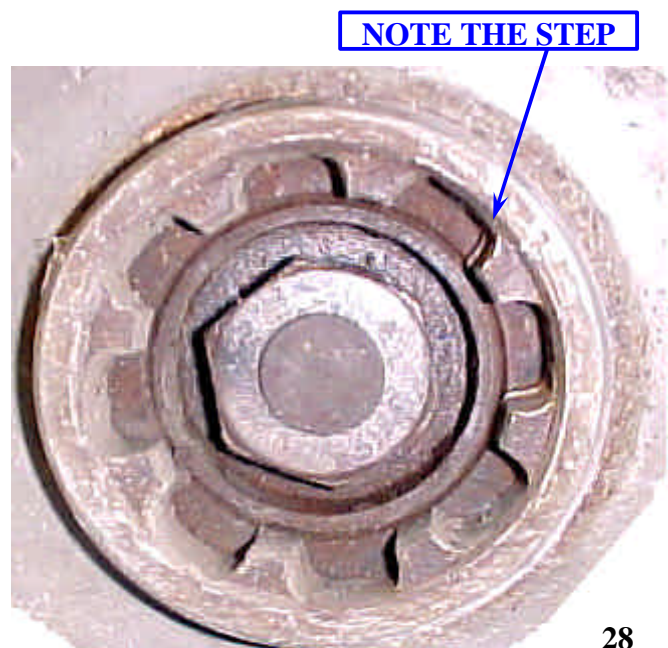

Note the sharp corners and square edges on a new feedscrew.

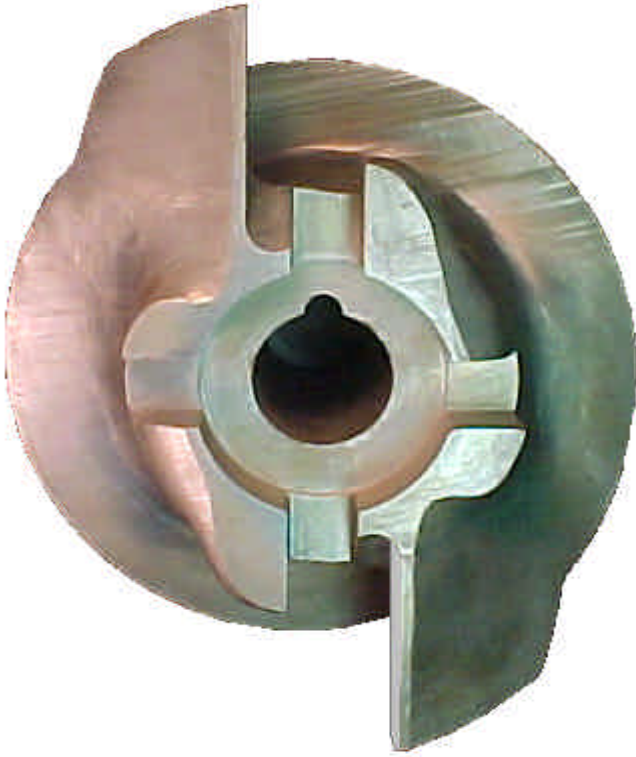

Sharp cupping is needed to aggressively grasp the product that falls into the hopper.

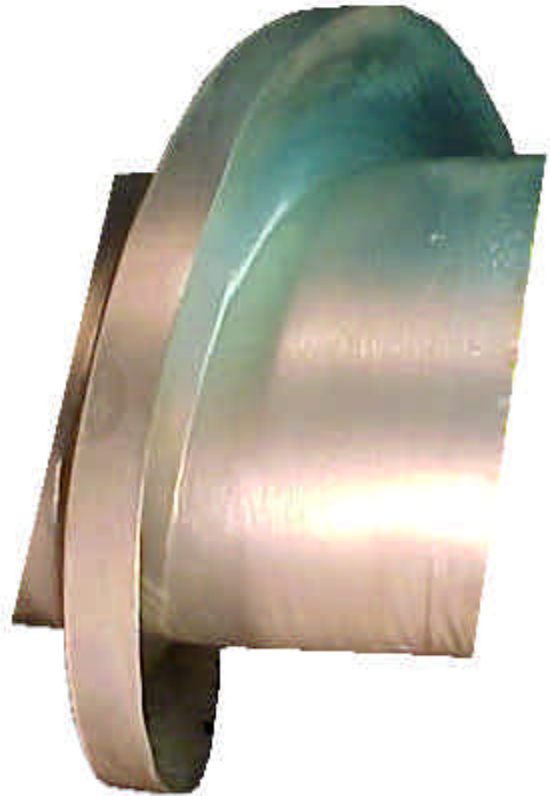

On a new or rebuilt feedscrew you will notice that the flighting is thicker. When new or rebuilt, the corners are square. Notice the nice fillet welds attaching the flighting to the shaft.

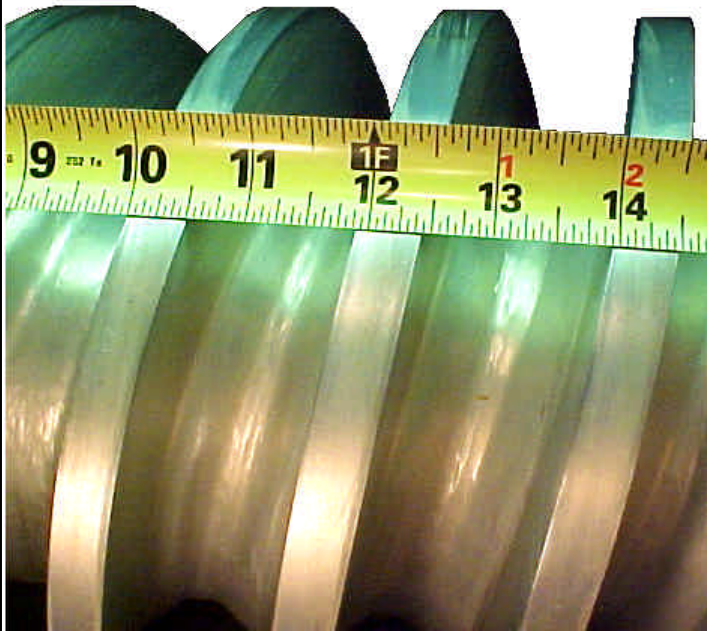

Shown below is a new drive spline with a thrust screw installed.

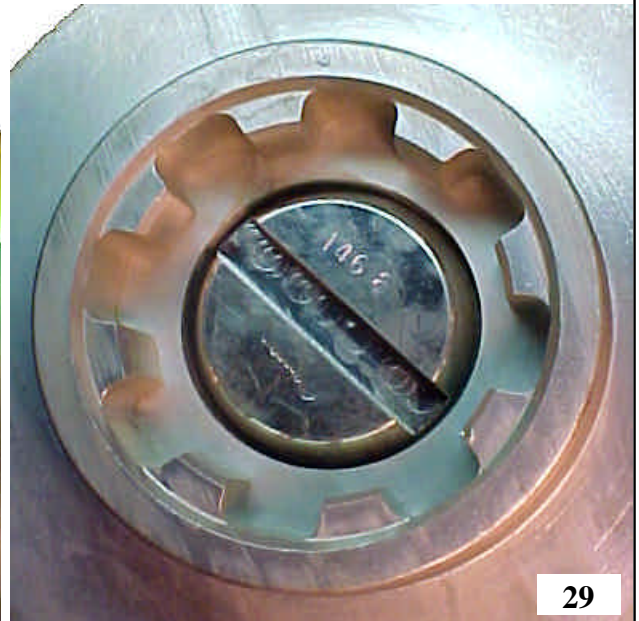

HOPPERS.

The spin ridge, which runs the length of the hopper at the bottom, should have a square corner. When this edge becomes rolled over, the feedscrew has difficulty feeding the head correctly. In time, the excluder seal will wear a ridge in the back flange of the hopper. The spin ridge and the seal area can be rebuilt.

Tin plated hopper wth new safety stickers.

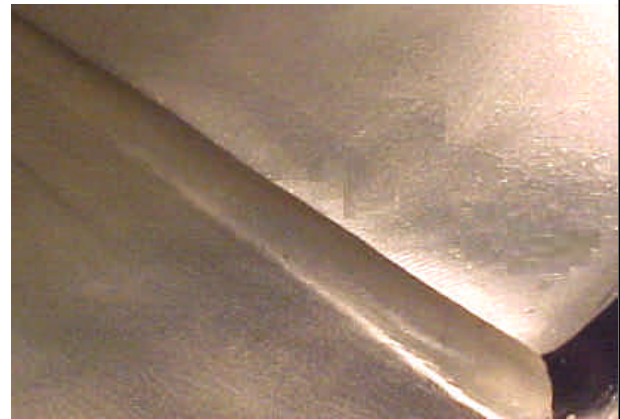
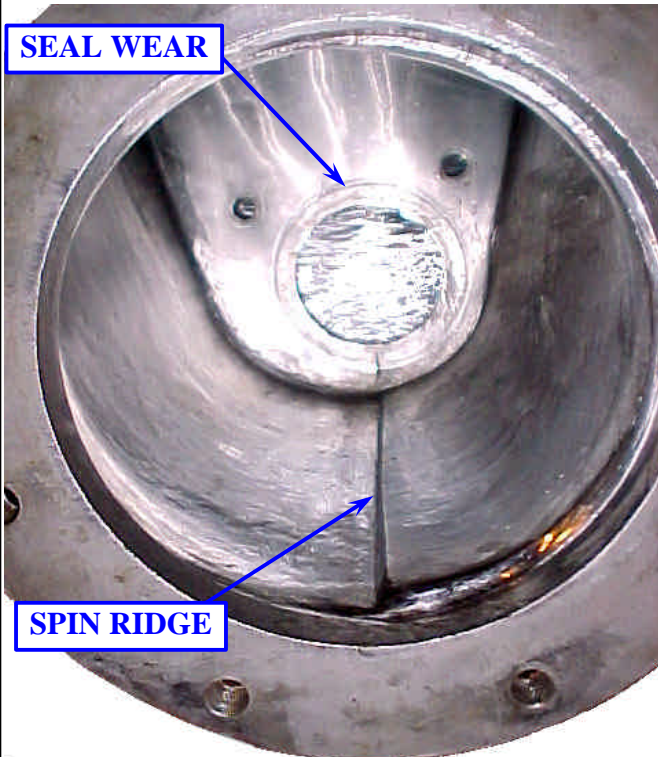

Detail of rebuilt spin ridge, note the sharp corner.

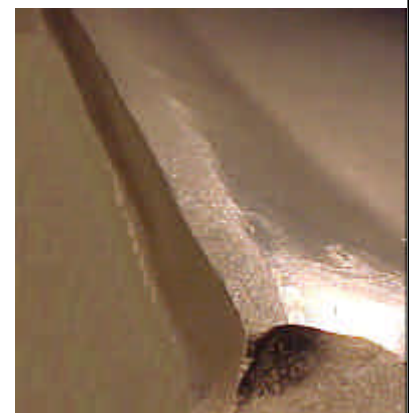
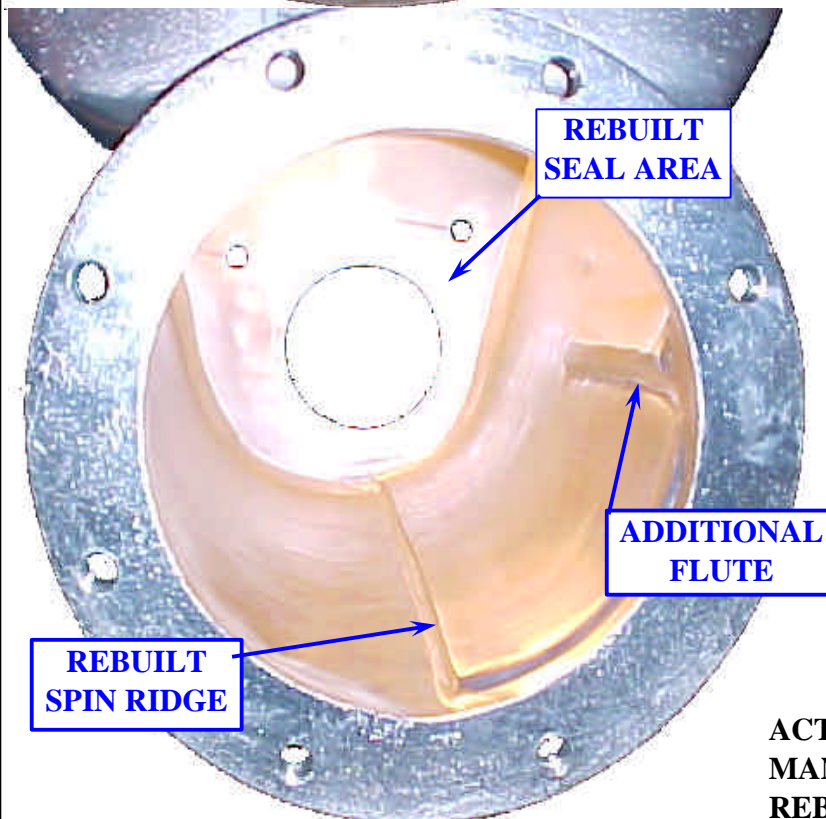

Detail of additional flute, note the sharp corner.

ACTUAL PHOTO OF HOPPER
MANUFACTURED IN 1973,
REBUILT 1999.